



## **CMV SHARPER FINISH**



### **Finish Master<sup>®</sup> 3000 With Built-In Folder**

*One of over 100 ironer models we manufacture*

# Imagine All Of The Possibilities

THE FINISH MASTER® IS THE MOST VERSATILE MACHINE IN ITS CLASS. DAMP LINEN FED INTO THE FINISH MASTER® IS DRIED, IRONED, RETURNED EITHER TO THE FRONT OR REAR, FOLDED OR FLAT, ALL AT THE CONTROL OF THE OPERATOR.

ALL OF THIS IS DONE USING SIMPLE CONTROLS. CMV SHARPER FINISH HAS ELIMINATED THE NEED FOR COMPLICATED SENSORS AND MEASURING EQUIPMENT.

THE FINISH MASTER® DELIVERS FOLDED LINEN THAT IS 18" (457 MM) WIDE. MODELS ARE AVAILABLE THAT WILL IRON, DRY, AND DELIVER TO THE FRONT ONLY OR TO EITHER THE FRONT AND REAR OF THE IRONER. THE FINISH MASTER® CAN EVEN FOLD ROUND LINENS.

## Front Delivery Operation

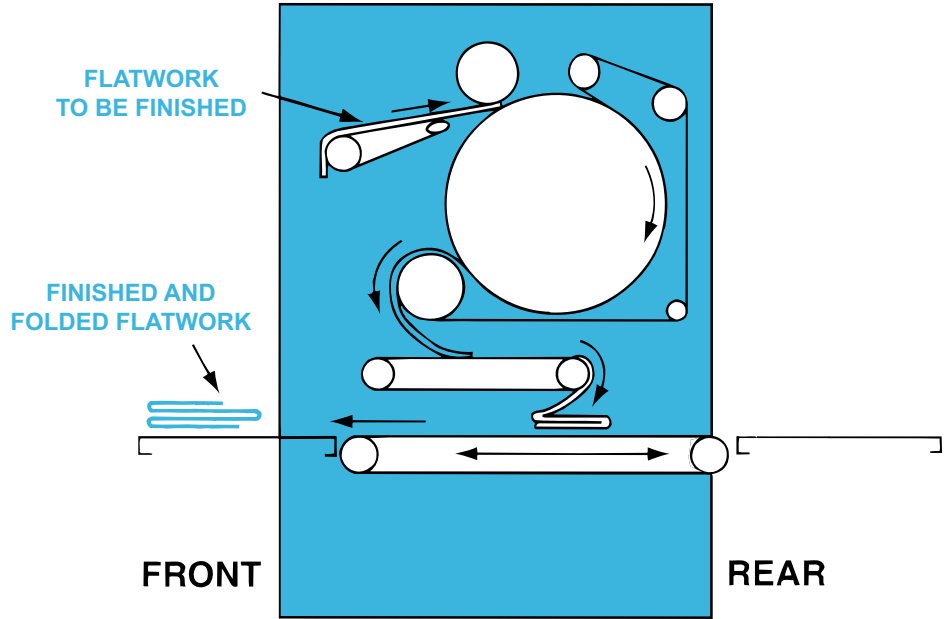

## Rear Delivery Operation

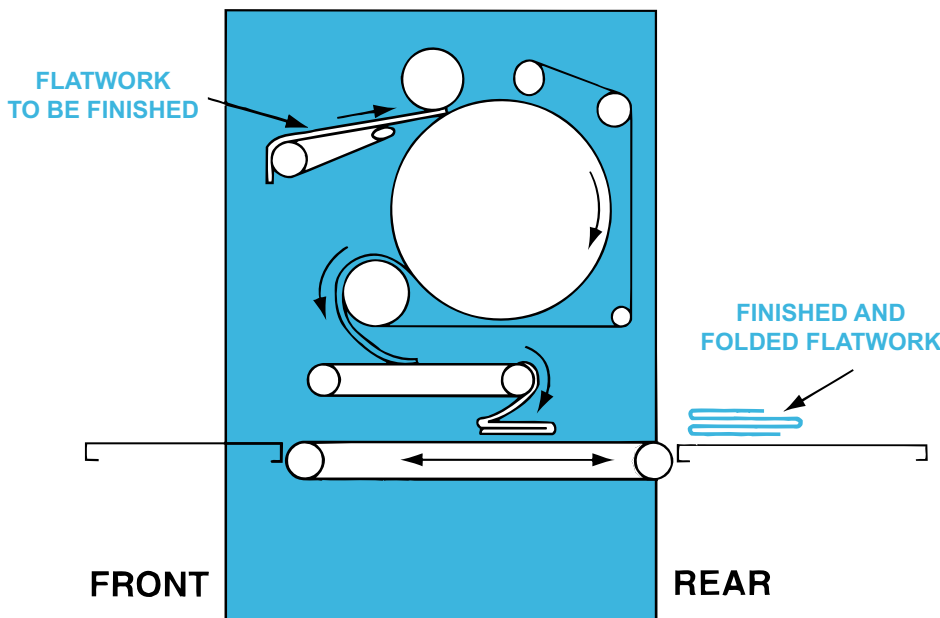

IRONED LINEN DELIVERED TO THE REAR ALLOWS YOUR LAUNDRY TO MORE THAN DOUBLE ITS IRONING PRODUCTION BY ADDING ONLY ONE OPERATOR. THE SINGLE OPERATOR AT THE REAR CAN CROSSFOLD AND STACK THE LINEN BECAUSE THE FOLDER HAS MADE THE JOB EASY FOR ONE PERSON TO HANDLE. THE FOLDER ELIMINATES THE NEED OF TWO OPERATORS AT THE REAR.

# Finish Master® Ironer with Built-In Accufold® Automatic Folder

## Features

► **Many Sizes.** 120" (3m) ironing width along with optional 132" (3353mm) and 136" (3454mm) widths. 16" (406mm), 20" (508mm), 24" (610 mm), 30" (763mm), or 36" (914 mm), diameter revolving heated cylinder.

► **Simplified.** Made by "The Ironer People"™. This is all we do and we do it well. You cannot find an ironer on the market that is less complicated than the Finish Master®. We work hard to simplify our design so you have less to worry about. The Finish Master® lets you do more with less.

► **Sturdy.** The "mean-green machine". We use thick gauge metal with steel welded construction. This makes the Finish Master® stronger than any other machine in its class, insuring a long life and maximum return on your investment. The entire machine is finished with a high grade "CMV Green" colored machine paint enamel.

► **Built-In Accufold®.** The built-in automatic primary folder increases production and reduces labor costs. The Finish Master® is the only machine that can fold round tablecloths. Folded linen can be removed from the front only or front and rear of the ironer.

► **Versatile.** Clearly the most versatile machine in its class. Adding one operator will more than double potential production.

► **Safety.** Safety features include front, rear, and side interlocked guards, 24V controls, full width hand guard, full width on/off switch cable, properly sized exhaust blower to vent moisture and harmful products of combustion, accurate thermostatic heat control with high temperature shutoff, high gas pressure shut-off switch, and numerous warning labels and instructions.

► **Heating.** The Finish Master® can be heated by gas, steam or electricity (Only Model 1600 and 2000 are available electrically heated.). The gas heated models are

equipped with the full width multi-port H.O.T.™ (Hold On Temperature) induced draft burner that evenly distributes the heat with a total of nine parts. Compare that to others burners using nearly fifty parts or those that heat oil and have two pumps and long piping to heat the ironer.

► **Quality ironing.** The Finish Master® ironer uses Nomex® padding and ribbons with automated pressure regulation to iron, dry, remove wrinkles, and fold.

► **Options.** Available options include inverter drive, chrome plated heated cylinder, and Intelatrol® II Monitoring System.

► **Intelatrol® Monitoring System.** It is standard on all gas and electrically heated models. We all need to be reminded of things from time to time. Have you ever forgotten to lock a door or turn off a light? Well, your laundry operator could forget to turn off the heat to your ironer, wasting energy and creating a hazard. They cannot forget if they have a Finish Master® equipped with the Intelatrol®. The Intelatrol® will shut off the heat after twenty minutes if the Finish Master® is left unattended. A red light will indicate that the Intelatrol® deactivated the heating system, greatly increasing the life of your ironer ribbons and padding.



## Features - Finish Master®

\*120" (3m) ironing width. 36" (914mm) diameter revolving heated cylinder, that can process 480 sheets per hour.\* Great for ironing high quality cotton sheets. Also available 132" (3352 mm) and 136" (3455 mm) wide.

\*Made by "The Ironer People"™. This is all we do and we do it well. You cannot find an ironer on the market that is less complicated than the Finish Master®. We work hard to simplify our design so you have less to worry about. The Finish Master® lets you do more with less.

\*The "mean-green machine". We use thick gauge metal with steel welded construction. This makes the Finish Master® stronger than any other machine in its class, insuring a long life and maximum return on your investment.

\*Folded linen can be removed from the front or rear of the ironer.

\*Clearly the most versatile machine in its class. Adding one operator will more than double potential production.

\*The Finish Master® can be heated by gas or steam. The gas heated models are equipped with the full width multi-port H.O.T.™ induced draft burner that evenly distributes the heat with a total of nine parts. Compare that to others burners using nearly fifty parts or those that heat oil and have two pumps and long piping to heat the ironer.

## Dimensions

Dimensions	
A	185" (4700 mm)
B	78" (1981 mm)
C	96" (2438 mm)
D	85" (2159 mm)
E	17" (431 mm)
F	50" (1270 mm)
G	18" (457 mm)
I	21" (533 mm)
K	28" (711 mm)

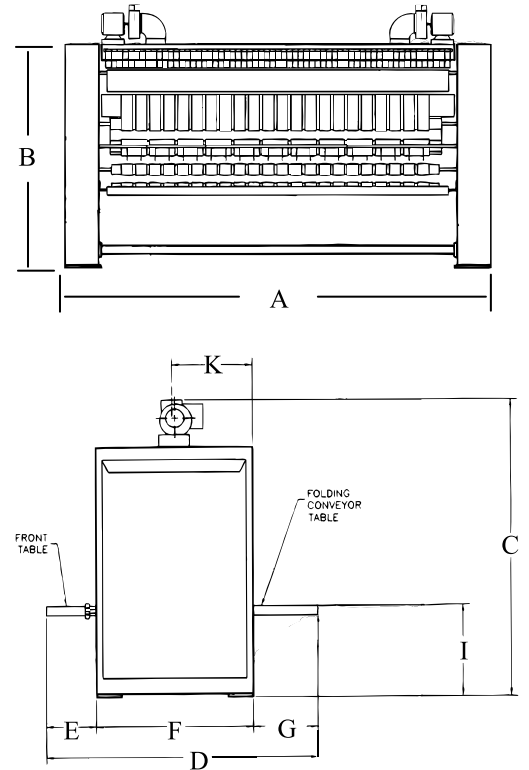

- ▶ Each canopy blower discharge is approximately 1050 C.F.M. at 1" S.P. Vent must be independent and not connected with any other vent line. Use 10" diameter vent.
  - ▶ Allow minimum of 24" (610 mm) clearance at ends of ironer for maintenance access.
  - ▶ Do not use for construction purposes unless certified correct by CMV Sharper Finish.
  - ▶ Available for any electrical specification.
  - ▶ Compressed air is required.
- \* Rear mode, assumes blended sheets at 25 % moisture retention

▶ © 2012 by CMV Sharper Finish, Inc. Form CMV932A In view of CMV's policy of providing the best products possible, CMV reserves the right to change specifications and appearance without notice. Contact the sales department for exact specifications, dimensions, and product approvals. CMV manufactures over 100 different ironer models that are sold throughout the world.

Technical Data	Model G/AF3000	Model S/AF3000
Finishing Surface Width-Inches (mm)	120 (3048)	120 (3048)
Heated Roll Diameter-Inches (mm)	30" (762)	30" (762)
Finishing Speed-Feet per minute (m/min)	20-100 (6.1-30.5)	25-70 (6.1-30.5)
Electrical Requirements-H.P. (kW)	3+ 2 x 1 (2.24 + 2 x .746)	3+ 2 x 1 (2.24 + 2 x .746)
Maximum Gas Input-B.T.U./hr. (Cal. kg/hr.)	495,000 (145)	-
Steam Consumption-Boiler H.P. (kg/hr.)	-	6.6 (108)
Net Weight-Pounds (kg)	7950 (3630)	8650 (3950)
Crated Weight-Pounds (kg)	8450 (3859)	9150 (4178)
Crated Size L x W x H-Inches (mm)	206 x 64 x 90 (5232 x 1626 x 2286)	206 x 64 x 90 (5232 x 1626 x 2286)
Crated Volume-Cubic Feet (m³)	686 (20.58)	686 (20.58)



CMV  
**Sharper Finish, Inc.**  
 4500 Augusta Boulevard  
 Chicago, Illinois 60651-3399 U.S.A.  
 Telephone: 773-276-4800  
 Facsimile: 773-276-6878  
 Email: sales@cmvsharperfinish.com

Distributed by:

Toll Free U.S.A. and Canada: 800-247-IRON